

GOOD NEWS CLUB AGENDA

LIFE OF CHRIST #17 – “Follow Jesus First”

WEEK OF:

MAIN TRUTH: Jesus should have first place in your life.

TO DO AS THE CHILDREN ARRIVE:

1. Greet the children; make them feel welcome.
2. Take attendance.
3. Listen to last week’s memory verse.
4. Have children put money in missions bank.

PRE-SESSION ACTIVITY:

1. OLDER CHILD: “When You Have Conviction”
2. YOUNGER CHILD: Life of Christ #17 Activity Sheet

SONG: (2 minutes)

PRAYER: (3 minutes)

1. Prayer song: _____
2. Ask the children to share any “Thank You Prayers” or “Please Prayers” they have.
3. Lead the children in “Thank You Prayers” and “Please Prayers.”

MEMORY VERSE: (6 minutes)

Matthew 6:33 - “But seek ye first the kingdom of God, and His righteousness; and all these things shall be added unto you.”

(The underlined portion of the verse indicates what the younger children should memorize.)

“Crazy Stand-ups” – Have different groups stand up to repeat the verse: those wearing blue, those who have a brother or a sister, those who like ice cream, those who brushed their teeth, etc. Try to choose a category that applies to as many children as possible.

HYMN FOR LIFE OF CHRIST #13 – #18: (2 minutes)

BIBLE LESSON: (20 minutes)

LIFE OF CHRIST #17 – “Follow Jesus First”

(See **Involvement Helps for Younger Children** for ways to involve the children in the Bible lesson.)

COUNSEL TIME:

(If you have a helper, hostess, or Teacher Junior Grade, let them do the review time while you counsel those who responded to the invitation. Otherwise, at the end of club, be sure to remind the children who responded to the invitation to stay after club for a few minutes.)

LEARNING ABOUT THE BIBLE & THE NEW TESTAMENT BOOKS: (6 minutes)

Teach information for Week #14. (See attached page.)

QUIET TIME NOTEBOOK: (1 minute)

From the returned TTtR/Q.T.N.s, mention one or two of the children's responses to the Main Truth challenge. Hand out Take Time to Review/Quiet Time Notebook, Life of Christ #17. Ask the children to complete the booklet before the next club. Remind them that they need to show you their TTtR/Q.T. Notebook next week.

MISSIONARY TIME: (14 minutes)

1. Sing "God's Way" while a child comes to look in the "Go and Tell" Box.
2. Share missionary information for Week #17 using the "Go and Tell" Box. (See attached pages.)
3. Pray for the missionary.
4. Show goal chart and mention the amount given so far.
5. Missions song: _____
6. Story: *Whiter Than Snow*. Review briefly. Then teach the part of the story for Week #7.

REVIEW ACTIVITY: (6 minutes)

Use the activity below or the Bible Learning Game from the "**Involvement Helps for Younger Children.**"

"Telling the Truth" – Prepare cherries, tree, and hatchets for the flannelboard. You will also need at least ten white squares, numbered 1-10 and four black squares. Put the white and black squares in a small paper bag. Place the tree in the center of the board and scatter cherries around it. Place one hatchet on each side of the board. Divide the class into two teams. When a child correctly answers a review question, he may reach into the paper bag and pull out one square. If a white square is pulled out, the number on it will tell how many cherries have been earned for that team. Place the cherries on the flannelboard by that team's hatchet. If the square is black, they must give four of their cherries to the other team. It may be hard for them to give up those cherries, but remember when you tell a lie, you may hurt someone much more than that. – By Rita L. Lobbell, *GIVE & TAKE*, January/February 1996.

Review questions for LIFE OF CHRIST #17:

1. **How would you describe the man in our lesson who came running to Jesus?** (Rich, young, ruler)
2. **What important question did the rich young ruler ask Jesus?** ("What must I do to get eternal life?")
3. **What did Jesus answer?** (Keep the commandments)
4. **What were some of the commandments Jesus told him to keep?** (Thou shalt not kill. Thou shalt not steal. Thou shalt not bear false witness [lie]. Honor your father and mother. Love your neighbor as thyself.)
5. **What did the young man say about that?** ("All these have I kept since I was a boy.")
6. **What else did Jesus tell him to do?** ("Sell all you have, give to the poor, and follow Me.")
7. **What was Jesus trying to help the young man understand?** (He had sinned. He needed to put Jesus first. There is nothing he could do to get eternal life.)
8. **What did the rich young ruler do?** (He went away sorrowful)
9. **What was most important to the rich young man, even more important than having eternal life?** (Money and things)
10. **What is the only way to have eternal life?** (Put your trust in Jesus for the forgiveness of sin)

*COUNSEL TIME: (*Only if you did not counsel with the children earlier.)

SEND HOME WITH THE CHILDREN:

1. Memory verse token.
2. Pre-session papers for older and younger child.
3. Take Time to Review/Quiet Time Notebook, Life of Christ #17

PRE-SESSION, Older Child – LIFE OF CHRIST #17

When You Have Conviction

 **Use these clues to remind yourself what conviction is. Write the letters on the lines to match the numbers.**

First word:

1. My first letter is in BUG, but not in RUG.

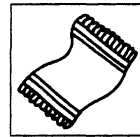
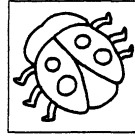

2. My second letter is in TREE, but not in TRY.

3. My third letter is in BELT, but not in BEET.

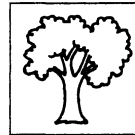

4. My fourth letter is in ICE, but not in ROSE.

5. My fifth letter is in EEL, but not in LOAF.

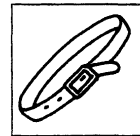

6. My sixth letter is in VELVET, but not in LETTER.

7. My seventh letter is in SHOULDER, but not in SHOULD.

Second word:

1. My first letter is in YES, but not in GUESS.

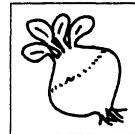

2. My second letter is in NO, but not in KNEW.

3. My third letter is in TURN, but not in TERN.

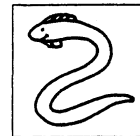

CONVICTION is showing that what you

is IMPORTANT to .



 **Put an X by the things that are important to you.**

___ Believing that Jesus is God's Son.

___ Doing things the way God teaches is the right way.

___ Going to church and reading the Bible.

___ Telling others about Jesus.

Name _____

PRE-SESSION, Younger Child – LIFE OF CHRIST #17

Draw his face.
Help him down
the road.



Jesus told the young man to sell his things
and follow Him. The young man became
 sad. He owned many things.

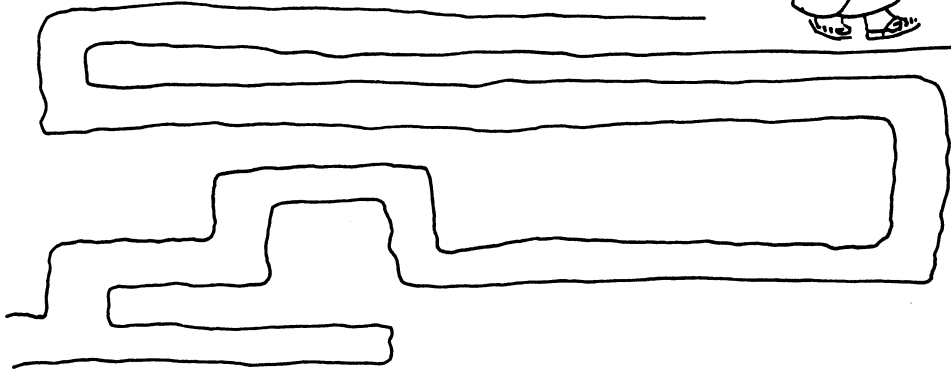

Jesus said,
“...you will
have treasure
in heaven.”

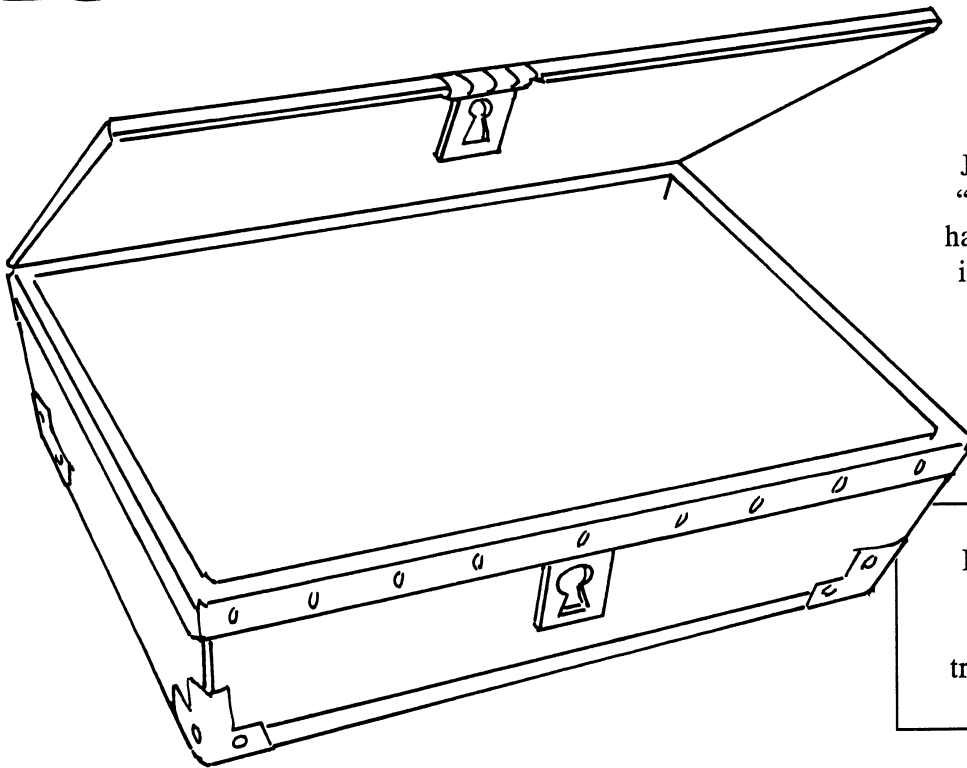

Draw things
you love
in the
treasure chest.

**“For by grace are ye saved through faith”
Ephesians 2:8**

Life of Christ #17
FOLLOW JESUS FIRST

Matthew 6:33

“But seek ye first the kingdom of God, and His righteousness; and all these things shall be added unto you.”

Introduction:

Cameron visited his friend Andre’s house. Andre’s family had a nice, big house, and Andre had his own room, cool sneakers, all the best toys. When Cameron came home to the small room he shared with his brothers, he complained, “It’s not fair! Andre’s family has so much more than we do. When I grow up, I’m going to be rich and buy a big house and everything I want.” *Things* were important to Cameron. How important are things to you? Our memory verse today tells us what God says about what should be most important.

Presentation:

Read the verse together from the visual. Then read the verse from the Bible.

Explanation:

Matthew 6:33 – This is the address of the verse. It’s where it’s found in the Bible.

“But seek ye first the kingdom of God,” – That means wanting with your whole heart to know God and His plan for your life. That should be what is most important to you.

“and His righteousness:” – Righteousness means right living, living the right way that God wants.

“and all these things” – Other things like houses and clothes and toys and even food.

“shall be added unto you.” – God will give you the things He knows you need for a life that pleases Him.

Repetition:

Crazy Stand-ups

Have different groups stand up to repeat the verse: those wearing blue, those who have a brother or a sister, those who like ice cream, those who brushed their teeth, etc. Try to choose a category that applies to as many children as possible.

HELPS FOR YOUNGER CHILDREN

Life of Christ #17

Memory Verse

For younger children, teach only the underlined portion of the verse.

Matthew 6:33– “But seek ye first the kingdom of God, and His righteousness; and all these things shall be added unto you.”

Bible Lesson Involvement Helps

Flashcard 5-1:

Ask some questions about how the children think the man got Jesus’ attention: “Do you think the man shouted to Jesus?” “Do you think he might have snapped his fingers?” “Is it possible he jumped up and down?” “Would he have whistled to make Jesus turn to him?”

Flashcard 5-3:

Have children run in place and then kneel.

Have children turn to the person sitting next to them, shrug their shoulders, and ask, “*What must I do to get eternal life?*”

Have the children motion with their hand, as if speaking to the young man, saying “*Come, follow Me.*”

Flashcard 5-6:

Have the children repeat after you these truths, one at a time: “I must admit that I have sinned.” “I cannot be saved by being good.” “Jesus is the only way to eternal life.”

Flashcard 5-5:

Have the children show you the expression on the young man’s face as he made the choice not to follow Jesus first. (*sadness; disappointment*)

Bible Learning Game (Adapted from “Button, Button”)

By Linda D. Ruth

Children sit in a circle, each clasping his hands together in front of him as if hiding something. Choose one child to go to a place away from the group and close and cover his eyes.

Go around the circle with a penny in your hand, pretending to put that penny into the hands of each child. The penny is actually only given to one child.

All the children must keep their hands tightly clasped together. After you have been around the circle of children, everyone says together, “*Penny, penny! Who has the penny?*” That’s the signal for the one who closed his eyes to return to the group. He has three tries to guess who has it.

Whether he guesses correctly or not, at the end of each child’s turn say, “*The young ruler’s money was important to him, more important than following Jesus. How important is it to you to follow Jesus?*”

Choose someone else to cover his eyes. Play again.

LEARNING ABOUT THE BIBLE & THE NEW TESTAMENT BOOKS

WEEK #15

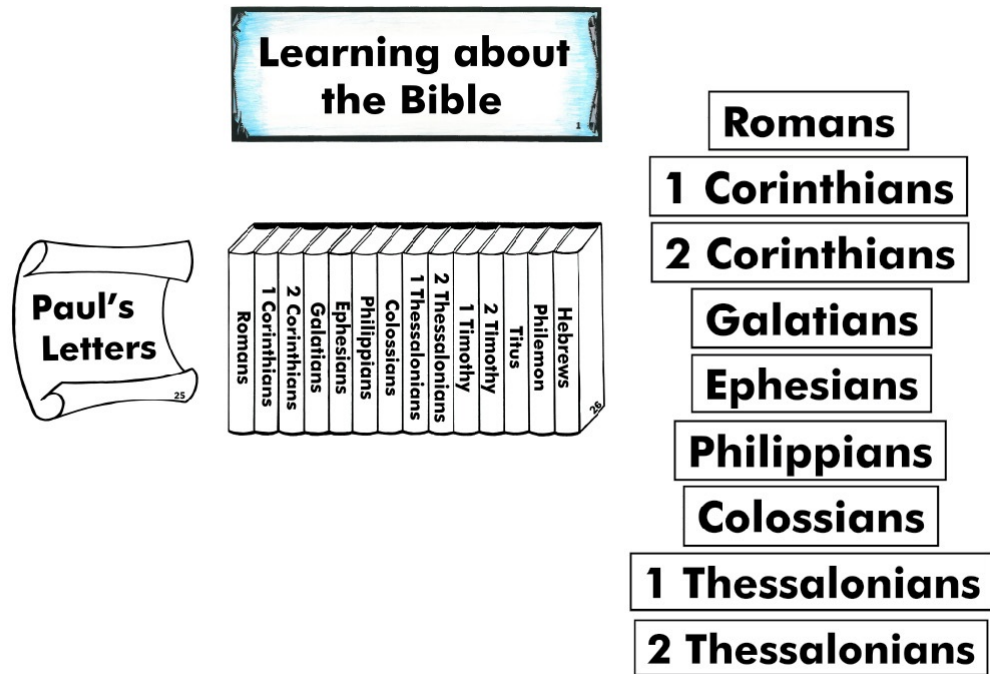

(Place figure #1.) (Review what we learned about in the four Gospels and in the book of History and that the next section of books is called Paul's Letters.) For the last couple of weeks, we have been learning some of the names of Paul's Letters. (Place figure #25.) How many letters did Paul write? (14.) (Place figure #26.) Let's say the names of the first seven of Paul's Letters. (Place Romans, 1 Corinthians, 2 Corinthians, Galatians, Ephesians, Philippians, and Colossians wordstrips.) Today, we are going to learn the names of two more letters. First and Second Thessalonians were written to the church at Thessalonica. (Place 1 Thessalonians and 2 Thessalonians wordstrips.) Now we have learned all the names of Paul's Letters that were written to churches or groups of believers. Let's say all nine of them together. (Practice together.) Remember, Paul wrote to these churches because there were believers in all of these places who needed to know how God wanted them to live. Now let's review all the names of the books of the New Testament that we have learned. (Practice several times saying the names of the four Gospels, the book of History, and the first nine books of Paul's Letters.)

HELPS FOR YOUNGER CHILDREN

Life of Christ #17

Memory Verse

For younger children, teach only the underlined portion of the verse.

Matthew 6:33– “But seek ye first the kingdom of God, and His righteousness; and all these things shall be added unto you.”

Bible Lesson Involvement Helps

Flashcard 5-1:

Ask some questions about how the children think the man got Jesus’ attention: “Do you think the man shouted to Jesus?” “Do you think he might have snapped his fingers?” “Is it possible he jumped up and down?” “Would he have whistled to make Jesus turn to him?”

Flashcard 5-3:

Have children run in place and then kneel.

Have children turn to the person sitting next to them, shrug their shoulders, and ask, “*What must I do to get eternal life?*”

Have the children motion with their hand, as if speaking to the young man, saying “*Come, follow Me.*”

Flashcard 5-6:

Have the children repeat after you these truths, one at a time: “I must admit that I have sinned.” “I cannot be saved by being good.” “Jesus is the only way to eternal life.”

Flashcard 5-5:

Have the children show you the expression on the young man’s face as he made the choice not to follow Jesus first. (*sadness; disappointment*)

Bible Learning Game (Adapted from “Button, Button”)

By Linda D. Ruth

Children sit in a circle, each clasping his hands together in front of him as if hiding something. Choose one child to go to a place away from the group and close and cover his eyes.

Go around the circle with a penny in your hand, pretending to put that penny into the hands of each child. The penny is actually only given to one child.

All the children must keep their hands tightly clasped together. After you have been around the circle of children, everyone says together, “*Penny, penny! Who has the penny?*” That’s the signal for the one who closed his eyes to return to the group. He has three tries to guess who has it.

Whether he guesses correctly or not, at the end of each child’s turn say, “*The young ruler’s money was important to him, more important than following Jesus. How important is it to you to follow Jesus?*”

Choose someone else to cover his eyes. Play again.

INFORMATION ABOUT THE LUTTMANNS

GO AND TELL BOX – WEEK #17

NAMES and ADDRESS:

Mr. & Mrs. Tom Luttmann
P.O. Box 153
Akron, PA 17501
Email: tom@biblevisuals.org

BIRTHDAYS:

Tom – December 16
Betsy – July 7
Elijah – January 7 (Born 2006)
Samuel – July 13 (Born 2007)
David – July 13 (Born 2007)
Jesse – October 7 (Born 2012)
Ginger – June 21 (Born 2014)

Suggested item to put in the “Go and Tell” Box – a picture of a guitar and a mandolin.

What do you think this picture of guitar and mandolin has to do with *going and telling*? (Let the children share their ideas.)

Today, we will learn more about another missionary family and their ministry of printing hymns and Bible materials.



INFORMATION:

Our missionaries today are **Mr. Tom and Mrs. Betsy Luttmann**. (*Show their family picture and have the children say their names as you point to them.*) They have four boys, Elijah (fourteen years old and in 9th grade), Samuel and David (thirteen-year old twins in 7th grade), and Jesse (eight years old and in 2nd grade). Ginger, their little girl (six years old and in 1st grade). Their children are homeschooled and also attend a homeschool hybrid (Firm Foundations Academy) that meets twice a week.

The Luttmann family loves music and art. Each one of the family members plays a musical instrument. Elijah is the artist of the family. He is learning to use some of the computer programs that BVI (Bible Visuals International) uses to create the illustrations for their Bible lessons and songs. Samuel plays the mandolin and David plays the banjo. David and Jesse play the piano. Ginger is in the process of picking what instrument to learn. Mr. Tom plays the euphonium and is working on picking up the guitar. Mrs. Betsy plays the cornet.

At home, the family is always busy. Right now, they are helping BVI on a new project supplying Bible curriculum to the public schools in the country of Papua New Guinea. The Luttmann family appreciate our prayers and support while they are working on this.

GOAL CHART POST OFFICE – WEEK #17

MISSIONARY PRAYER REQUESTS

Dear God, thank You for Mr. Tom and his family and for Mr. Tom as he shares with others about Jesus.

Dear God, help Mr. Tom as he works on providing Bible curriculum to the public schools in Papua New Guinea.

Dear God, please help us and others give so that Mr. Tom and BVI will have the money to print new materials.

LOC REVIEW GAME
Telling the Truth

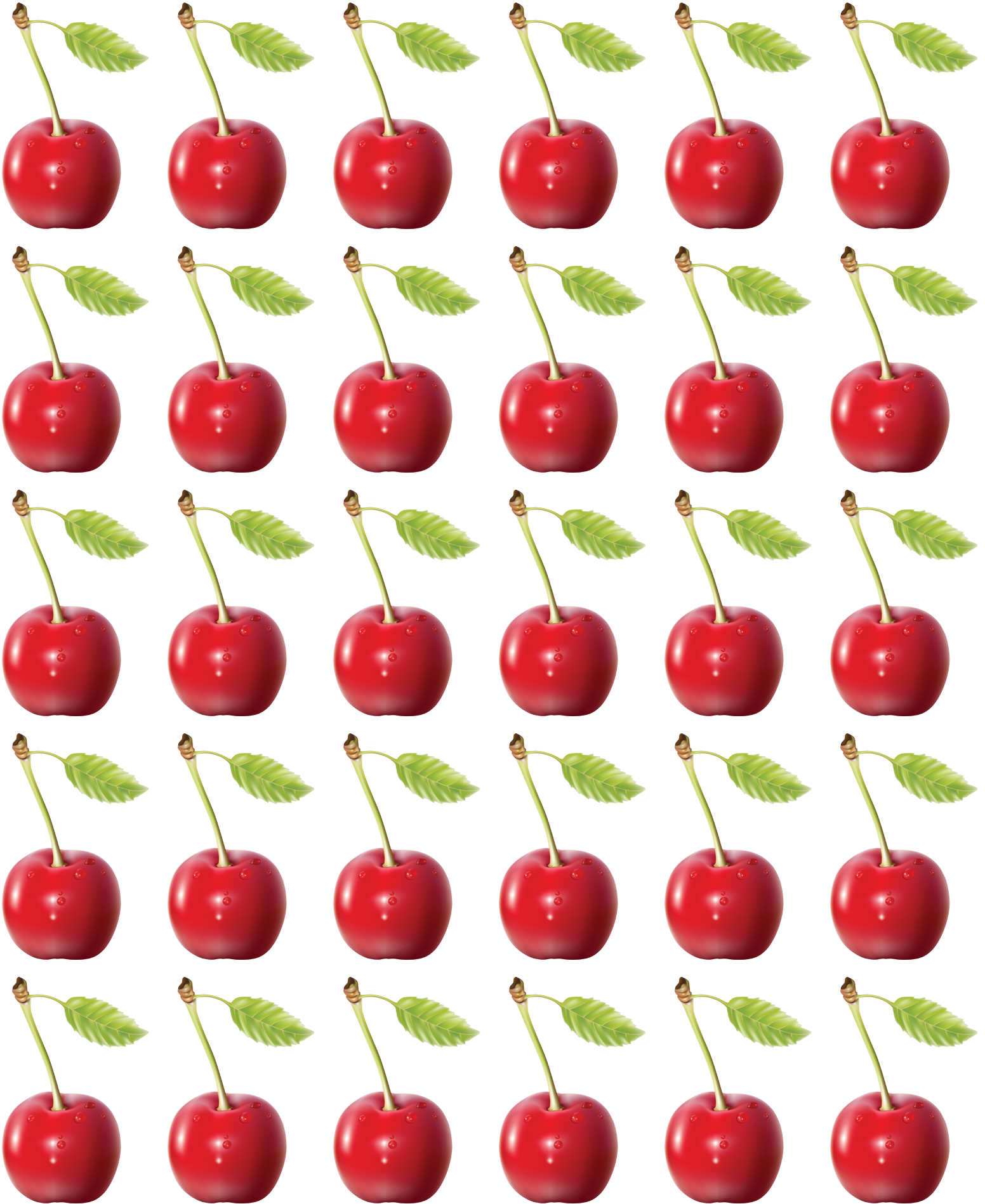

LOC REVIEW GAME
Telling the Truth



**Jesus
should
have first
place in
your life.**



- For this man, money was more important to him than anything else in the world . . .
- Even more than Jesus and eternal life
- Because he chose riches rather than Jesus, he went away very sorrowful (sad)
- Money was more important to him than anything else . . .
- More important than Jesus. More important than eternal life. More important than anything
- Truly, he was a *poor* rich man
- Jesus turned to His disciples, "How difficult it is for those who are rich to get into the Kingdom of God . . ."
- ". . . It is easier for a camel to go through the eye of a needle."
- Disciples wondered, "Who then can be saved?"
- Jesus answered to help them understand, "With man it is impossible, but with God, all things are possible."
- A rich man could be saved and have eternal life
- The only way to have eternal life for anyone is to put their trust in Jesus for the forgiveness of sin
- Perhaps you are wondering how you can have eternal life

INVITATION

Acts 16:31 – *"Believe on the Lord Jesus Christ, and thou shalt be saved. . . ."*

**S
P, E
L**

BOW HEADS RESPONSE

CHALLENGE

G – Go over **MT**

JESUS SHOULD HAVE FIRST PLACE IN YOUR LIFE

R – Review PAS verse

Matt. 6:33 – *"But seek ye first the kingdom of God, and His righteousness; and all these things shall be added unto you."*

O – Overview PAS examples

- 1.
- 2.
- 3.

W – Will you do it?

LIFE OF CHRIST #17

Matthew 19:16-26; Mark 10:17-27;
Luke 18:18-27

- I want you to think for a moment. Don't say anything out loud
- What is of great value to you? What would you put in 1st place, as most important, if you had to choose?
- Some things are worth more to one person than another
- Perhaps by the end of our lesson, you will understand the best answer to the question

MT – JESUS SHOULD HAVE FIRST PLACE IN YOUR LIFE

- A man in the Bible had a question for Jesus
- Jesus made the man choose what was most important to him. Did he put Jesus first?

FLASHCARD 5-1

- The young man ran up to Jesus. Perhaps he had heard about Jesus or listened to His teaching
- He seemed to know that Jesus was Someone very important. There was something different about Him

O

- This young man probably didn't know Jesus was God's Son, but he seemed to know Jesus was important

- Jesus stopped what He was doing to see what the man wanted

- Jesus knew the man had a need, and He wanted to help. He loved this young man very much

G

FLASHCARD 5-2

- Bible tells us the young man was rich. Probably had nice clothes
- He was a ruler, perhaps a leader in the synagogue. Probably well-educated

FLASHCARD 5-3

- Young man knelt before Jesus
- Disciples watched what happened, may have wondered why he would kneel before Jesus
- Jesus knew. He knew the man's heart

- The young man had good clothes and good education, but he wasn't happy, wasn't satisfied

- God made us so we can never truly be happy without a relationship with Him

- There is something that separates us from a relationship with Jesus. It is sin

S, PAU

Isaiah 53:6 – *"All we like sheep have gone astray; we have turned every one to his own way"*

1. - Jesus knew the man thought he could be saved by the things he did
2. - Jesus also knew the man could never obey all the commandments all the time
3. - Young man asked, "Which commandments?"
- Jesus, "Thou shalt not kill. Shalt not steal. Shalt not bear false witness. Honor father and mother. Love thy neighbor as thyself."
- Man, "I have kept these since I was a boy. What else do I need?"
- Do you think he had always obeyed all of these commandments?
- No! He could not have. He was a sinner just like us
- He was not willing to admit that he was not putting God first in his life

MT, PAS – JESUS SHOULD HAVE FIRST PLACE IN YOUR LIFE

Matt. 6:33 – "But seek ye first the kingdom of God, and His righteousness; and all these things shall be added unto you."

- 1.
- 2.
- 3.

- You and I should want more than anything else to do the things that show Jesus has first place in our lives
- The young man in our story was not putting Jesus first
- His possessions and money were too important to him
- Bible says Jesus looked at the man and loved him
- Jesus wanted him to have eternal life
- Jesus, "You need one thing. Go and sell everything you have. Give the money to the poor . . .
- . . . Then you will have treasure in Heaven. Do this, then come follow Me."
- Did Jesus mean a person could get eternal life in Heaven if they gave everything away to the poor?
- No, because that would be working to earn a place in Heaven

FLASHCARD 5-6

- Jesus was trying to get the young man to understand he needed to put Jesus first
- There is nothing the man could do to get eternal life
- Jesus provided the only way to eternal life when He died on the cross

**P, E
1 Cor. 15:3 – ". . . Christ died for our sins according to the Scriptures. . . ."**

- Jesus was trying to help the man understand how to have eternal life
- How was Jesus going to get the young ruler to see and understand his own sin
- When Jesus said the young man must love his neighbor as himself, He waited to see what the man would do
- If the man loved others the way he loved himself, he would be willing to sell his possessions and give money to the poor
- Would he do this? Would he tell Jesus, "I see what You mean. I do not love others the way I love myself. I have sinned."
- The disciples were standing by watching. What would the man do?

FLASHCARD 5-4

- They saw the young man's expression change. His face suddenly became sad
- He knew he didn't want to do what Jesus said

FLASHCARD 5-5

- As he thought about his riches, the young man knew he didn't want to give them all away